

Chain Block - Bulldog



- Super strength alloy loadchain.
- Fully machined liftwheel.
- Minimum headroom.
- Minimum effort to raise maximum load.
- Cast steel safety latches.
- Lower hook complete with thrust race.
- Fully enclosed gear train.
- Weather protected automatic Weston brake with unique Twin Pawls.
- Galvanised handchain as standard.



Standard: EN 13157: 2004

Loadsafe Overload Protection

Certex have introduced overload protection for their quality range of lever hoists and chain blocks. When lifting with conventional blocks there is no safeguard incorporated in the design of the chain block for the prevention of overload damage.

Unfortunately it is all too common practise to extend the leverage by adding either a longer pipe to the lever hoist handle or using additional personnel to increase the manual effort on the hand chain when the lifting effort becomes too great.

The Bulldog range has a simple solution that prevents a load being lifted if it is excess of a preset level. Using a special clutch mechanism, this prevents the equipment from being damaged by overloading.

Certex are the pioneers in offering this feature as standard for their range of chain blocks and lever hoists. As the additional cost to the operator will be minimal this offers a full proof safety system in the prevention of damage to the equipment by overloading, thus avoiding expensive repair costs

- Features:** Lightweight robust construction.
- Material:** Chain and Hook Grade 8
- Marking:** WLL, code and CE marking.
- Finish:** Durable baked enamel paint protection

Safety factor: 4:1

Select a row from the table below, then click the add to quote button

Part Code	WLL ton	Lifting height m	effort to lift SWL	clearance dimensions mm a headroom	clearance dimensions b width mm	clearance dimensions. c depth mm	clearance dimensions mm hook opening upper	clearance dimensions mm hook opening lower	Load chain Ø mm	Number of falls	Weight kg
06A0020	0,5	6	23 kg	270	127	131	30	30	6	1	10
06A0010	0,5	3	23 kg	270	127	131	30	30	6	1	10
06A0040	1	6	30	317	158	140	28	28	6	1	12
06A0030	1	3	30 kg	317	158	140	28	28	6	1	12
--	1,5	3	32 kg	399	187	161	36	36	8	1	13
06A0080	2	6	35 kg	414	187	161	33,5	33,5	8	1	22
06A0070	2	3	35 kg	414	187	161	33,5	33,5	8	1	22
06A0120	3	6	32 kg	465	210	161	40	40	8	2	27
06A0110	3	3	32 kg	465	210	161	40	40	8	2	27
06A0140	5	6	41 kg	636	253	161	50	50	10	2	46
06A0150	10	6	39 kg	750	373	184	64	64	10	4	

• N.B. Specifications and dimensions for 20 t available on application.

1

Add to quote

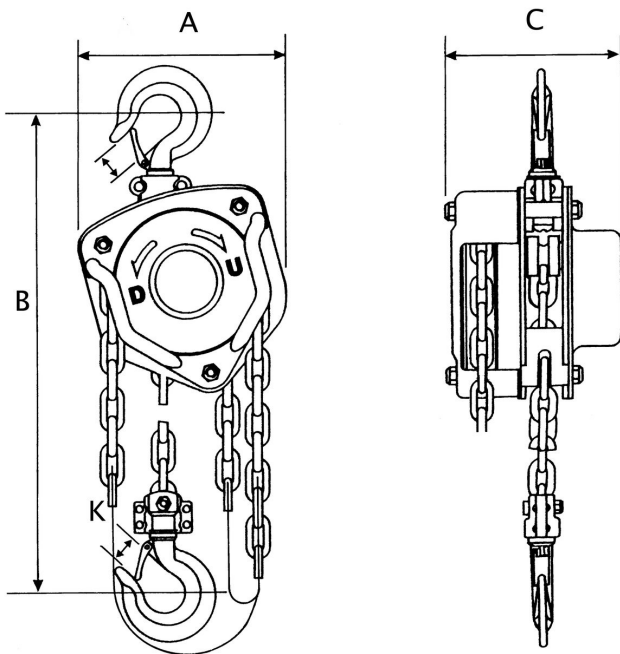

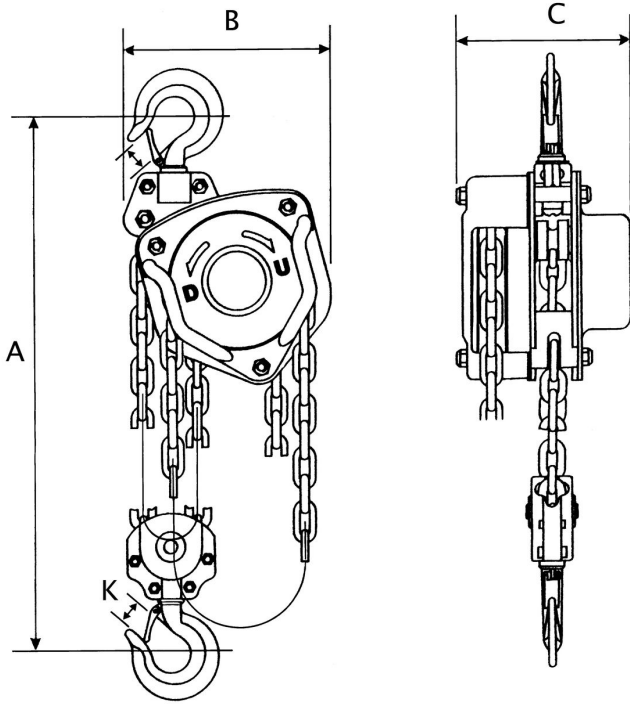

Unit C1, Harworth Industrial Estate
Bryans Close
Harworth
Doncaster
DN11 8RY

[01302 756 777](tel:01302756777)
info@certex.co.uk