

# Lifting Magnet BM



## BM BATTERY-POWERED LIFTING MAGNET WITH REMOTE CONTROL

The BM battery lifting magnet complete with remote control is a suitable tool for handling on premises where it is otherwise difficult to operate a lifting device manually. The remote control operates up to a distance of 10 metres. It is also used for cutters and flame cutting machines when handling metal sheets and loads up to 5000 kg.

### Advantages:

- New control unit with functions such as Variable Force (to adjust the holding force when handling a particular quantity of sheet-metals from a stack) and Tip-Off (for gradual slackening of part of the load, e.g. thin sheet metal products, such as sheeting)
- Besides the buttons on the magnet body, the unit can also be controlled using the IR remote control from up to 10 metres away
- Universal steel lifting eye
- Safety – synoptic display with battery level LED indicator, blocking of cutting-off during lifting, audible and visual warning signals indicate low battery level

BM is a series of lifting magnets with a battery power supply and high lifting capacities. The magnet is conformable with a safety factor of 2:1, i.e. it can carry more than double its maximum allowed lifting capacity in the tear-away test

Handling using the magnet is very simple and, due to its remote control, it is also comfortable. Altogether, we offer 4 models with different lifting capacities, where the BM3600 model is suitable especially for handling thin metal plates with a thickness of more than 3 mm. Power is provided by a 12V built-in battery allowing up to 8 hours of operating time at 50% duty cycle.

There is a safety switch under the lifting eye to prevent switching off during lifting. It is not possible to activate the magnet once the battery voltage drops below the safety level. Additionally, low battery is indicated by visual and audible alarms.

**Material:** Solid magnetic base with durable embedded coil.

**Marking:** According to standard

**Temperature range:** max. 50 °C

**Standard:** EN 13155

**Note:** Battery: 12 V. Battery life: 8 hours at 50 % cycle

**Safety factor:** 2:1



Select a row from the table below, then click the add to quote button

Part Code	WLL ton	Model	L x W of base (mm)	Height up to crane hook (mm)	Built in battery V/Ah	Type of battery	Weight kg
--	1.35	BM 1350	272 x 242	460	12V / 35 Ah	FG12 - 35 D	60
--	2.5	BM 2500	400 x 242	460	12V / 75 Ah	FG12 - 75 D	72
--	3.6	BM 3600	1050 x 240	460	12V / 75 Ah	FG12 - 75 D	180
--	5	BM 5000	1200 x 300	460	12V / 75 Ah	FG12 - 75 D	203

1

Add to quote

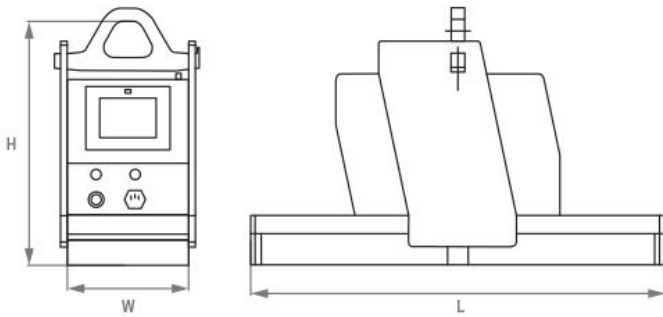

Unit C1, Harworth Industrial Estate  
Bryans Close  
Harworth  
Doncaster  
DN11 8RY

[01302 756 777](tel:01302756777)  
[info@certex.co.uk](mailto:info@certex.co.uk)