

## Swivel Hoist Ring HR-125 UNC

### Product information



Available in UNC and Metric thread sizes.

UNC threads available in sizes from 650 pounds to 29,000 pounds Working Load Limit, with a design factor of 5 to 1.

Metric threads available in sizes from 300kg to 13,000kg and dual rated in both a 4 to 1 and 5 to 1 design factor.

360° swivel and 180° pivot action.

100% individually proof tested to 2 1/2 times the Working Load Limit with certification and Statistically Magnetic Particle inspected. (Can be furnished 100% Magnetic Particle inspected when requested at time of order). Bolts are individually Proof Tested.

Fatigue rated to 20,000 cycles at 1 1/2 times the Working Load Limit.

Bolt is secured with patented retaining ring which requires no modification to threads. This method allows for easy disassembly and assembly of hoist ring for thorough examination of all components. Replacement kits are available.

Top washer has the following features: The Working Load Limit and Recommended Torque value are permanently stamped into each washer.

**Design:** Crosby

[... Read more](#)

**Features:** Rated at 100% at 90° angle

**Material:** Alloy Steel - Quenched and Tempered

**Marking:** Product Identification Code (PIC) for material traceability along with a working Load Limit and the name Crosby or "CG" stamped into it.

**Finish:** Washer is colour coded for easy identification Silver Metric thread

**Safety factor:** 5:1

## Swivel Hoist Ring HR-125 UNC

### Blueprint

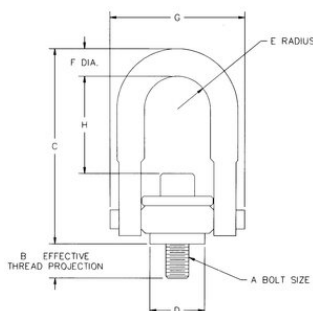

### Technical data

Part code	WLL ton	Thread Inch	Torque Nm	C mm	D mm	E mm	F mm	G mm	H mm	B mm	Weight kg
42151016887	0.363	5/16 - 18 x 1.50	10	69.1	24.6	11.7	8.6	47.5	28.4	14.7	0.17
42151016898	0.454	3/8 - 16 x 1.50	16	69.1	24.6	11.7	8.6	47.5	26.7	14.7	0.18
42151016909	1.134	1/2 - 13 x 2.00	38	123	49.8	22.1	19	85.1	58.2	17.8	1.06
42151016912	1.134	1/2 - 13 x 2.50	38	123	49.8	22.1	19	85.1	58.2	30.5	1.07
42151016920	1.814	5/8 - 11 x 2.00	81	123	49.8	22.1	19	85.1	54.9	17.8	1.09
42151016924	1.814	5/8 - 11 x 2.75	81	123	49.8	22.1	19	85.1	54.9	36.8	1.12
42151016931	2.268	3/4 - 10 x 2.25	136	123	49.8	22.1	19	85.1	51.8	24.1	1.14
42151016935	2.268	3/4 - 10 x 2.75	136	123	49.8	22.1	19	85.1	51.8	36.8	1.17
42151016942	3.175	3/4 - 10 x 2.75	136	167	75.2	34.5	23.9	124	75.4	22.6	3.05
42151016946	3.175	3/4 - 10 x 3.50	136	167	75.2	34.5	23.9	124	75.4	41.7	3.09
42151016953	3.629	7/8 - 9 x 2.75	217	167	75.2	34.5	23.9	124	72.1	22.6	3.1
42151016957	3.629	7/8 - 9 x 3.50	217	167	75.2	34.5	23.9	124	72.1	41.7	3.16
42151016964	4.536	1 - 8 x 3.00	312	167	75.2	34.5	23.9	124	69.1	29	3.22
42151016969	4.536	1 - 8 x 4.00	312	167	75.2	34.5	23.9	124	69.1	54.4	3.32
42151016975	6.804	1-1/4 - 7 x 4.50	637	221	94.2	44.5	30.2	157	99.8	56.1	6.58
42151016986	10.89	1-1/2 - 6 x 6.75	1,085	315	120	60.7	44.5	215	143	3	17.1
42151016997	13.61	2 - 4-1/2 x 6.50	1,491	315	120	60.7	44.5	215	131	3	18.5
42151017001	22.68	2-1/2 - 4 x 8.0	2,847	429	146	76.2	57.2	279	204	102	39.9
42151017005	34.02	3 - 4 x 10.5	5,830	495	184	95.3	69.9	360	216	127	75.3
42151017009	45.36	3-1/2 - 4 x 13.0	6,915	561	197	102	82.6	404	236	178	120